

EXAMPLE PART NUMBER: 49 B 4 A 4 - 15 - 09

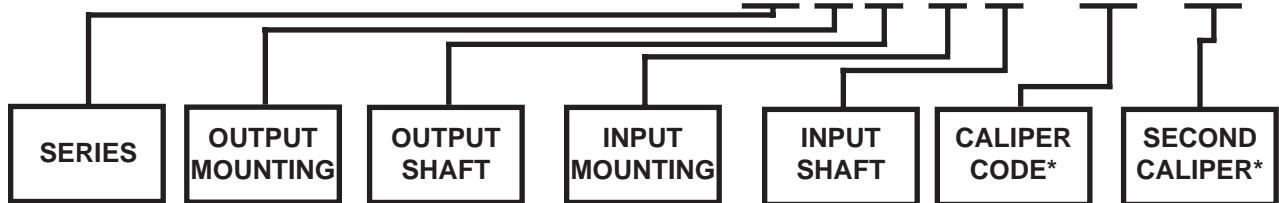

*Indicates next to last digits in caliper Part Number 01-266-0_ _0. A second caliper is optional.

49B CALIPER BRAKE SERVICE & REPAIR MANUAL

THIS SERVICE MANUAL IS EFFEC-
TIVE
FROM: S/N 57755, SEPT. 1998
TO: CURRENT

49B SERVICE MANUAL

CALIPER BRAKE

This manual will assist in disassembly and assembly of Eskridge Model 49B brakes. Item numbers, indicated in parentheses throughout this manual, refer to the exploded parts breakdown drawing. Individual customer specifications (mounting case, output shaft, brake assembly, etc.) may vary from exploded drawing and standard part numbers shown. If applicable, refer to individual customer drawing for details.

For any spare or replacement parts, contact your distributor or equipment manufacturer. Always try to have available the unit part number, serial number and date code on the serial tag. This information may be necessary for verification of any component part numbers. Component part numbers and/or manufacturing lot numbers may be stamped on individual parts. This information may also be helpful in identifying replacement components.

MAINTENANCE

The Model 49B Series is a modular SAE 'B'-mounted caliper disc brake. It is designed to accept a MICO, Inc. 515 series caliper which is available in three basic models: mechanical-apply, hydraulic-apply and spring-apply/hydraulic-release. The brake housing will accept one or two calipers. This allows calipers to be selected to meet a variety of applications that may require both a service brake and a parking brake. The disc is aluminum-bronze for corrosion resistance in exposed applications. The shaft is supported at the output end by a bearing protected by a lipseal. The input end of the shaft must be supported by a hydraulic motor. A variety of motor mounts and shaft spline combinations are available.

Caliper Code	Eskridge P/N	Description	Torque per Caliper (In-Lb)	Limits
15	01-266-0150	Hydr.-Apply (MICO 02515030)	3.5 X Cylinder PSI.	2000 PSI Max*
08	01-266-0080	Mech.-Apply (MICO 02515148)	30 X Lever Pull (Lb)	420 LB Max
14	01-266-0140	Spring-Apply (MICO 02515002)	400-800 (Adjustable)	120-240 PSI Release*
09	01-266-0090	Spring-Apply (MICO 02515004)	800-1200 (Adjustable)	230-370 PSI Release*
17	01-266-0170	Spring-Apply (MICO 02515008)	1200-3200 (Adjustable)	340-910 PSI Release*
13	01-266-0130	Spring-Apply (MICO 02515006)	3200-4000 (Adjustable)	900-1200 PSI Release*

All hydraulic calipers (apply & release) are rated for 1500 PSI Continuous, 2000 PSI Intermittent.
Use only petroleum base hydraulic oil.
Minimum useable disc thickness is .375 inches/9.53 mm (New = .500 inches/12.70 mm).

WARNING: While working on this equipment, wear adequate protective clothing, hearing, eye, and respiratory protection. Use safe lifting procedures.

CONTENTS

Maintenance.....	2
Installation.....	3
Adustment of Calipers	3
Break In	3
Disassembly.....	3
Reassembly.....	3
Exploded view.....	5

Installation

- 1) Use only SAE grade 5 or better fasteners for mounting brake and motor.
- 2) Allow at least one bolt diameter of thread engagement when selecting fastener lengths. Be sure fasteners will not bottom out when fully tightened.
- 3) Orient brake as required for best orientation of hydraulic lines or cable linkage (mechanical-apply). If two calipers are provided, their positions may be switched as desired.
- 4) Mounting of the brake unit requires removal of the caliper(s) and disc. Remove one of the capscrews from caliper(s) and swing the caliper(s) out away from the disc. Remove the retaining ring **(8)** from the top of the disc and slide the disc up and off of the shaft.
- 5) Two mounting-hole patterns are provided: a 2-hole pattern on a 5.75 inch bolt circle and a 4-hole pattern on a 5.00 inch bolt circle. Either pattern may be used with single-caliper units. On units with two calipers, fasteners in the 4-hole pattern will interfere with the calipers at the two holes nearest the calipers.
- 6) See chart for fastener torque specifications.

THREAD SIZE	TORQUE IN FT-LBS			
	SAE GRADE 5		SAE GRADE 8	
	DRY	LUBED	DRY	LUBED
3/8-16	30	23	45	35
1/2-13	75	55	110	80
5/8-11	150	110	220	170
3/4-10	260	200	380	280

- 7) The retaining ring at the top of the disc has a beveled face. Reinstall the ring with the beveled face up or away from the disc. *Note: Newer models may use a spiral type retaining ring in lieu of a beveled ring. When reinstalling the spiral ring, it must be fully seated (the entire perimeter of the ID must be captured beneath the edge of the beveled shaft groove)*
- 8) Reinstall the caliper retaining bolts making sure that the caliper is free to float with the disc.

Adjustment of Calipers

Refer to the appropriate MICO *Installation and Service Instructions* for details concerning your caliper(s).

- 1) When attaching hydraulic lines, note that the hydraulic-apply caliper (with green piston body) has a 1/8-27 NPT port. The spring-apply/hydraulic-release caliper has a No. 4 SAE O-ring port and is furnished with a JIC 37°-flare elbow fitting.
- 2) It is critical that the caliper(s) be free to float after adjustment of the threaded piston body to desired torque (spring-applied) or recommended running clearance between brake linings and disc (hydraulic & mechanical-apply). The elbow that is provided with the spring-apply/hydraulic-release caliper must clear the brake housing while in the released position.
- 3) Use only mineral base hydraulic oil to pressurize hydraulic type calipers. They are not designed for use with SAE brake fluids. Brake fluids will attack and destroy the internal rubber seals.

- 4) Bleed any air from hydraulic caliper(s) and line.

Break In

- 1) Like automotive type disc brakes, the Model 49B will not produce repeatable braking until it is properly broken in or "burnished". Burnishing occurs at an elevated temperature of approximately 450° F (230° C).
- 2) Make sure that the disc is free of oil and grease before burnishing.
- 3) Generally speaking burnishing is accomplished by slipping the disc for approximately 200 revolutions at 2000 In-Lb of torque or 100 revolutions at 4000 In-Lb of torque, etc. The brake linings will emit a noticeable odor when burnishing temperature is reached.
- 4) It is important that burnishing be done relatively quickly and that the disc not exceed the above recommended temperature. Excess temperatures for a prolonged period of time can damage the rubber lipseal **(11)** between the brake housing and shaft.
- 5) Refer to the enclosed bulletin, MICO *Burnishing Procedures for Caliper Disc Brakes*, Form No. 81-950-016, for further details.

Disassembly

- 1) Remove hexhead capscrew **(5)** and caliper(s) **(10, 13)**.
- 2) Remove beveled retaining ring **(8)** and slide disc **(3)** up and off of shaft **(2)**. *Note: Newer models may use a spiral type retaining ring in lieu of a beveled ring.*
- 3) Remove capscrews **(14)** and remove brake assembly from its mounting.
- 4) Remove retaining ring **(6)** from housing **(1)**.
- 5) Position housing **(1)** with output end up. Press shaft **(2)** out of bearing **(4)**.
- 6) Remove retaining ring **(9)** from housing **(1)**.
- 7) Using a 1.63 to 1.75" diameter press tool, press the shaft **(2)** out of bearing **(4)**. The shaft **(2)** may be used as a press tool but this will destroy lipseal **(11)**.
- 8) Press the lipseal **(11)** from the housing **(1)**.
- 9) Clean and inspect all parts. Refer to the exploded drawing for P/N's of seal kit and replacement pad kit. Replacement parts and calipers assemblies are available through Eskridge Customer Service. Refer to the MICO bulletin and contact MICO customer service for caliper individual replacement parts.

Reassembly

- 1) Press a new lipseal **(11)** into housing **(1)**. Pack lipseal with grease.
- 2) Pack bearing **(4)** with grease and press into housing **(1)** with shielded end away from lipseal **(11)**.
- 3) Install retaining ring **(9)**.
- 4) From input end, press shaft **(2)** through lipseal **(11)** and

into bearing **(4)**. This will likely roll under the outer lip on the lipseal. To correct this, press the shaft back out approximately 1/16 inch. Then press back into place. **Important:** Do not apply excess force when pressing bearing. Excess force may cause bearing balls to yield the inner or outer races. This will cause the bearing to run rough.

- 5) Install retaining ring **(6)** on shaft **(2)**.
- 6) Reassemble all remaining parts in reverse of the Disassembly steps above. Note that the lower disc retaining ring **(7)** has no beveled face. The upper retaining ring **(8)** is the same size but may have a beveled face. The beveled face must be up, away from disc. *Note: Newer models may use a spiral type retaining ring in lieu of a beveled ring. When reinstalling the spiral ring, it must be fully seated (the entire perimeter of the ID must be captured beneath the edge of the beveled shaft groove)*
- 7) Perform the Break In (burnishing) procedure if the disc **(3)**, the caliper(s) **(10, 13)** or the lining pads have been replaced.

THE BRAKE IS NOW READY TO USE.

The caliper for this brake is manufactured by MICO. For a file containing the below MICO forms, which may apply to your brake's caliper, call Eskridge at 913-782-1238 and request TB49B-MICO-AA for MICO literature supporting the caliper.

MICO Form No. 81-600-001, *General Guidelines for Installing Hydraulic Brake Components*

MICO Form No. 81-950-016, *Burnishing Procedures for Caliper Disc Brakes*

MICO Form No. 81-515-007, *Installation and Service Instructions, Spring Apply Caliper Brakes*

MICO Form No. 81-515-008, *Installation and Service Instructions, Hydraulic Apply Caliper Brakes*

MICO Form No. 81-515-009, *Installation and Service Instructions, Mechanical Caliper Brakes*

CODE	CALIPER OPTION	PART NO.
08	CALIPER - MECH. APPLY	01-266-0080
09	CALIPER - SPRING APPLY	01-266-0090
13	CALIPER - SPRING APPLY	01-266-0130
14	CALIPER - SPRING APPLY	01-266-0140
15	CALIPER - HYD. APPLY	01-266-0150
17	CALIPER - SPRING APPLY	01-266-0170

X49B-AB,LDW
EFFECTIVE
FROM S/N 57755 9-15-98
TO: CURRENT

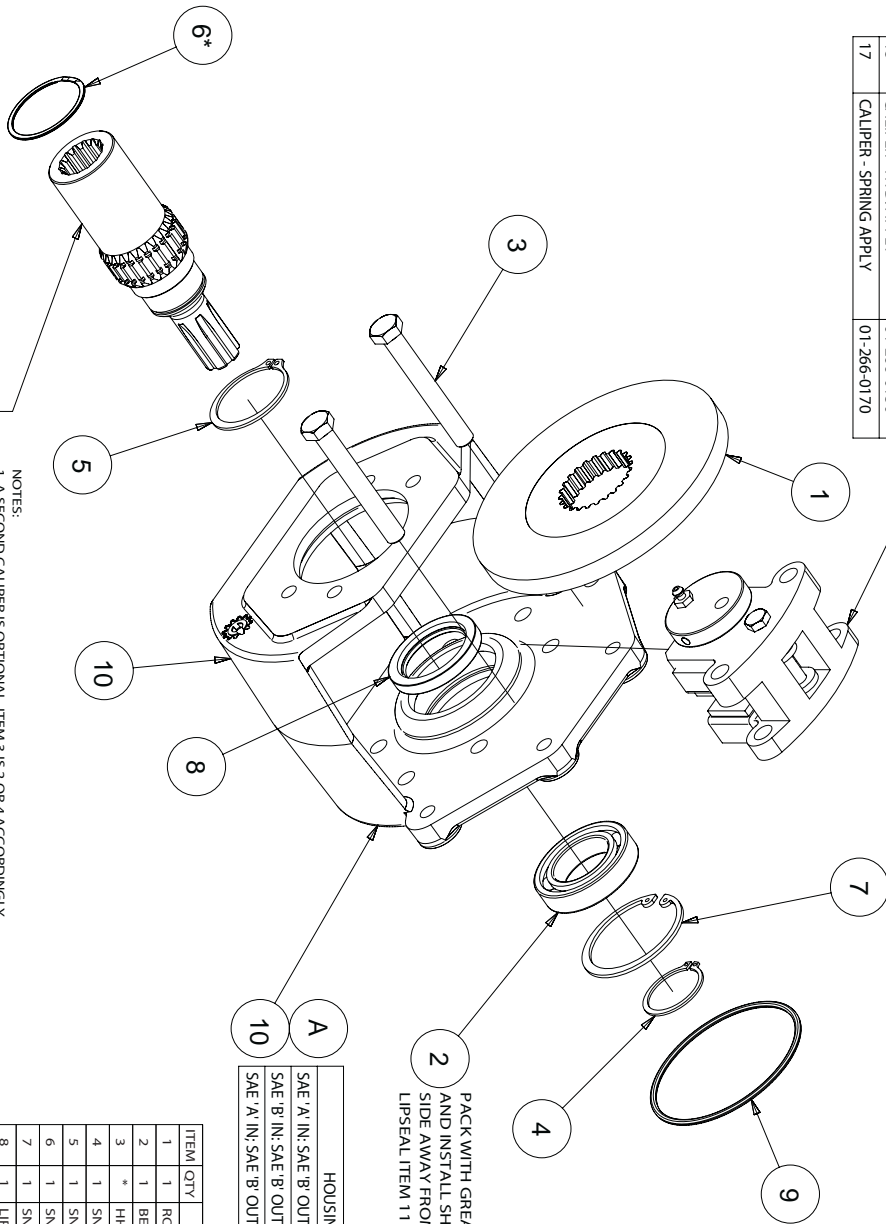

PACK WITH GREASE
AND INSTALL SHIELDED
SIDE AWAY FROM
LIPSEAL ITEM 11

HOUSING PILOT		PART NO.
SAE 'A' IN; SAE 'B' OUT		49-004-2073
SAE 'B' IN; SAE 'B' OUT		49-004-2083
SAE 'A' IN; SAE 'B' OUT, DUAL CALIPER		49-004-2084

ITEM QTY	DESCRIPTION	P/N
1	ROTOR - BRONZE	49-004-1122
2	BEARING (#6008)	01-100-0180
3	HHCS (1/2-1.3 x 3.75 GR8)	01-150-1250
4	SNAP RING (5100-156)	01-160-0110
5	SNAP RING (5100-206)	01-160-0250
6	SNAP RING (5102/WST-206)	01-160-0450
7	SNAP RING (3000-268)	01-160-0100
8	LIP SEAL (NAT 472164)	01-405-0170
9	O-RING (#242)	01-402-0220
10	HOUSING ASSY	-A-
11	SHAFT	-B-
12	* CALIPER	-C-

SHAFT OPTIONS		PART NO.
14T 12/24 IN: 14T 12/24 OUT		49-004-1193
14T 12/24 IN: 13T 16/32 OUT		49-004-1183
14T 12/24 IN: 1-48 OUT		49-004-1173

- NOTES:
1. A SECOND CALIPER IS OPTIONAL, ITEM 3 IS 2 OR 4 ACCORDINGLY.
 2. HOUSING IS PROVIDED WITH 2 & 4 BOLT PATTERNS FOR UP TO 6 MOUNTING CAPSCREWS, WITH DUAL CALIPERS. 2 CAPSCREWS IN 4 BOLT PATTERN WILL INTERFERE WITH CALIPERS.
 3. CALIPER MAY BE MOUNTED IN MIDDLE POSITION (AS SHOWN), OR EITHER SIDE POSITION.
 4. MINIMUM USABLE ROTOR THICKNESS IS .375" (NEW = 0.500").
 5. SEAL KIT IS P/N 49-01601201 (INCLUDES ITEM 8 & 9) REPLACEMENT PAD KIT (ALL CODES) IS P/N 01-266-0160. ONE KIT PER CALIPER. CALIPER (ITEM 12) MUST BE REPLACED AS A UNIT. NO SEAL KIT IS AVAILABLE.
 6. ITEM 6 MAY BE EITHER A MULTITURN SPIRAL RETAINING RING, OR A BEVELED SNAPRING. WHEN USING BEVELED RING, BEVELED EDGE MUST FACE AWAY FROM DISC.