

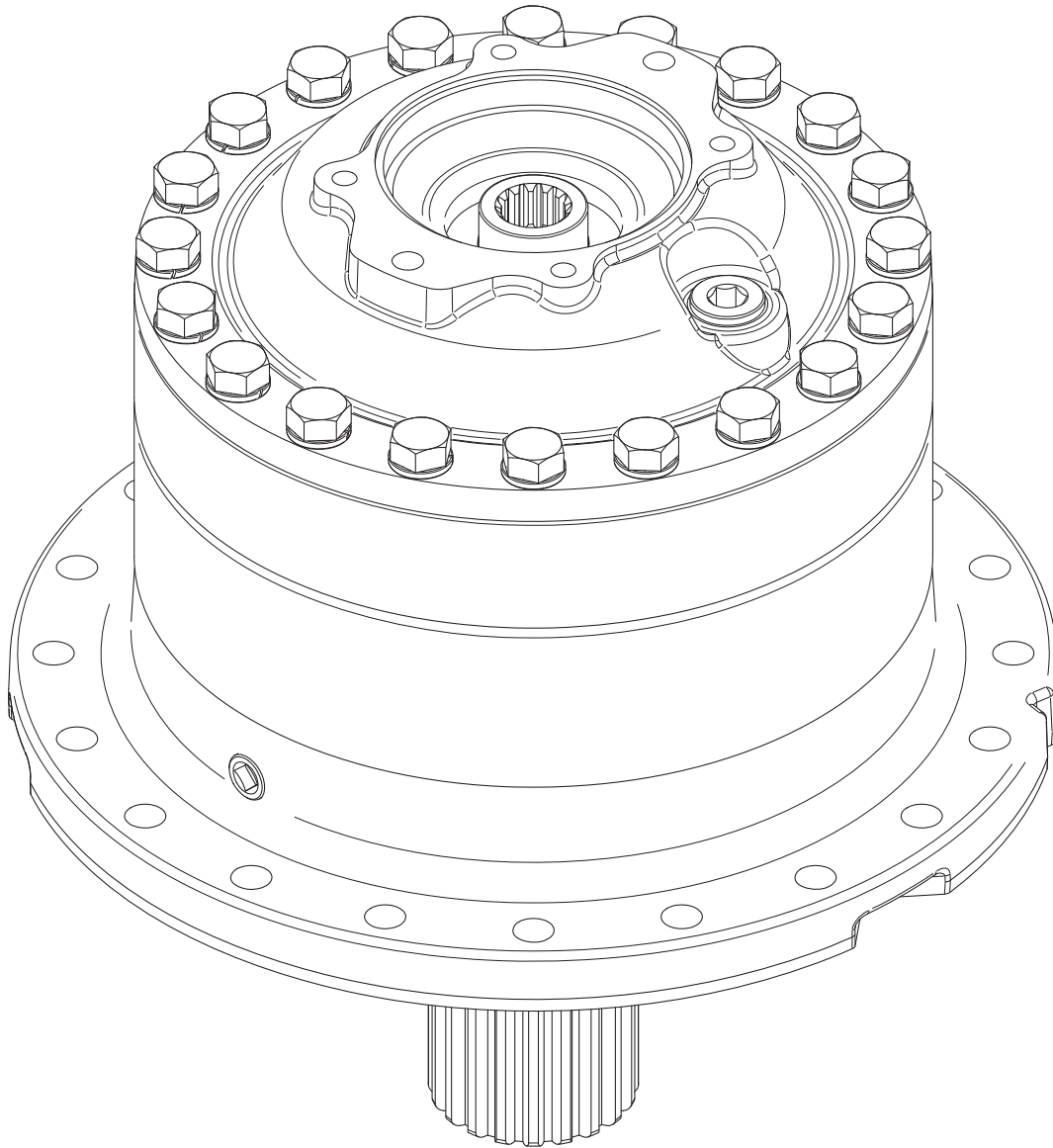

MODEL 250L PLANETARY GEAR DRIVE SERVICE MANUAL



WARNING: While working on this equipment, use safe lifting procedures, wear adequate clothing and wear hearing, eye and respiratory protection.

THIS SERVICE MANUAL IS EFFECTIVE:
S/N: 28500 TO CURRENT
DATE: 1/4/1997 TO CURRENT
VERSION: SM250LD2-AC

NOTE: Individual customer specifications (mounting case, output shaft, brake assembly, etc.) may vary from exploded drawing and standard part numbers shown. If applicable, refer to customer drawing for details.



ESKRIDGE

MODEL 250L

EQUIPPED WITH "LOAD-N-LOCK"[®] SHAFT RETENTION SYSTEM.

| ITEM | QTY | DESCRIPTION | RATIO → | | | | | |
|---|-----|---------------------------------------|---------------------------------|-------------------------------|-------------------------------|-----------------------------|---------------------------------|-------------------------------|
| | | | 20.25:1 4.3125:1 4.6957:1 | 25.88:1 4.3125:1 6.00:1 | 29.58:1 6.30:1 4.6957:1 | 37.80:1 6.30:1 6.00:1 | 40.25:1 8.5714:1 4.6957:1 | 51.43:1 8.5714:1 6.00:1 |
| EFFECTIVE: FROM: S/N 28500 01/01/97 TO: CURRENT | | | PART NO. | PART NO. | PART NO. | PART NO. | PART NO. | PART NO. |
| 1 | 1 | 250A BASE - ROUND | 25-004-3042 | 25-004-3042 | 25-004-3042 | 25-004-3042 | 25-004-3042 | 25-004-3042 |
| | | 250F BASE - FLANGELESS | 25-004-3052 | 25-004-3052 | 25-004-3052 | 25-004-3052 | 25-004-3052 | 25-004-3052 |
| | | 250Q BASE - ECCENTRIC PILOT | 25-004-3132 | 25-004-3132 | 25-004-3132 | 25-004-3132 | 25-004-3132 | 25-004-3132 |
| | | CUSTOM BASE | - | - | - | - | - | - |
| 2 | 1 | RING GEAR - PRIMARY | 25-004-1012 | 25-004-1012 | 25-004-1012 | 25-004-1012 | 25-004-1012 | 25-004-1012 |
| 3 | 1 | RING GEAR - SECONDARY | 25-004-1022 | 25-004-1022 | 25-004-1022 | 25-004-1022 | 25-004-1022 | 25-004-1022 |
| 4 | 1 | A - SAE 'A' COVER | 25-005-2061 | 25-005-2061 | 25-005-2061 | 25-005-2061 | 25-005-2061 | 25-005-2061 |
| | | B - SAE 'B' COVER | 25-005-2051 | 25-005-2051 | 25-005-2051 | 25-005-2051 | 25-005-2051 | 25-005-2051 |
| | | C - SAE 'C' (2 AND 4 BOLT) | 25-004-1222 | 25-004-1222 | 25-004-1222 | 25-004-1222 | 25-004-1222 | 25-004-1222 |
| | | D - SAE 'D' COVER | 25-004-1232 | 25-004-1232 | 25-004-1232 | 25-004-1232 | 25-004-1232 | 25-004-1232 |
| 5 | 1 | CARRIER - PRIMARY | 25-004-1052 | 25-004-1052 | 25-004-1042 | 25-004-1042 | 25-004-1032 | 25-004-1032 |
| 6 | 1 | CARRIER - SECONDARY | 25-004-1072 | 25-004-1062 | 25-004-1072 | 25-004-1062 | 25-004-1062 | 25-004-1062 |
| 7 | 1 | D1 - OUTPUT SHAFT 20T 6/12 SPLINE | 25-004-4032L | 25-004-4032L | 25-004-4032L | 25-004-4032L | 25-004-4032L | 25-004-4032L |
| | | D2 - OUTPUT SHAFT 3.75" DIA, KEYED | 25-004-4042L | 25-004-4042L | 25-004-4042L | 25-004-4042L | 25-004-4042L | 25-004-4042L |
| | | S1 - OUTPUT SHAFT SPINDLE, 9" PILOT | 25-004-4062L | 25-004-4062L | 25-004-4062L | 25-004-4062L | 25-004-4062L | 25-004-4062L |
| | | C1 - OUTPUT SHAFT - CUSTOM | - | - | - | - | - | - |
| 8 | 3 | PLANET GEAR - SECONDARY | 25-004-1092 | 25-004-1082 | 25-004-1092 | 25-004-1082 | 25-004-1092 | 25-004-1082 |
| 9 | 1 | SUN GEAR - SECONDARY | 25-004-1152 | 25-004-1142 | 25-004-1152 | 25-004-1142 | 25-004-1152 | 25-004-1142 |
| 10 | 3 | PLANET GEAR - PRIMARY | 25-004-1122 | 25-004-1122 | 25-004-1112 | 25-004-1112 | 25-004-1102 | 25-004-1102 |
| 11 | 1 | INPUT GEAR INPUT 14T SPL | 25-004-1202 | 25-004-1202 | 25-004-1172 | 25-004-1172 | 25-004-1162 | 25-004-1162 |
| | | INPUT GEAR INPUT 13T SPL | 25-004-1292 | 25-004-1292 | 25-004-1282 | 25-004-1282 | 25-004-1272 | 25-004-1272 |
| 12 | 3 | PLANET SHAFT - SECONDARY | 25-004-1021 | 25-004-1021 | 25-004-1021 | 25-004-1021 | 25-004-1021 | 25-004-1021 |
| 13 | 3 | PLANET SHAFT - PRIMARY | 25-004-1031 | 25-004-1031 | 25-004-1031 | 25-004-1031 | 25-004-1031 | 25-004-1031 |
| 14 | 2 | THRUST WASHER - CARRIER | 25-004-1132 | 25-004-1132 | 25-004-1132 | 25-004-1132 | 25-004-1132 | 25-004-1132 |
| 15 | 3 | SEAL (O-RING) | 01-402-0020 | 01-402-0020 | 01-402-0020 | 01-402-0020 | 01-402-0020 | 01-402-0020 |
| 16 | 6 | THRUST WASHER - PRI. PLANET | 81-004-1561 | 81-004-1561 | 81-004-1561 | 81-004-1561 | 81-004-1561 | 81-004-1561 |
| 17 | 6 | THRUST WASHER - SEC. PLANET | 25-004-1041 | 25-004-1041 | 25-004-1041 | 25-004-1041 | 25-004-1041 | 25-004-1041 |
| 18 | 1 | SPLIT RING - LOAD-N-LOCK | 25-004-1182 | 25-004-1182 | 25-004-1182 | 25-004-1182 | 25-004-1182 | 25-004-1182 |
| 19 | 1 | BEARING CONE - OUTER | 01-102-0120 | 01-102-0120 | 01-102-0120 | 01-102-0120 | 01-102-0120 | 01-102-0120 |
| 20 | 1 | BEARING CUP - OUTER | 01-103-0110 | 01-103-0110 | 01-103-0110 | 01-103-0110 | 01-103-0110 | 01-103-0110 |
| 21 | 1 | BEARING CONE - INNER | 01-102-0250 | 01-102-0250 | 01-102-0250 | 01-102-0250 | 01-102-0250 | 01-102-0250 |
| 22 | 1 | BEARING CUP - INNER | 01-103-0250 | 01-103-0250 | 01-103-0250 | 01-103-0250 | 01-103-0250 | 01-103-0250 |
| 23 | 3 | BEARING - SEC PLANET GEAR | 01-105-0550 | 01-105-0550 | 01-105-0550 | 01-105-0550 | 01-105-0550 | 01-105-0550 |
| 24 | 3 | BEARING - SEC PLANET GEAR | 01-105-0560 | 01-105-0560 | 01-105-0560 | 01-105-0560 | 01-105-0560 | 01-105-0560 |
| 25 | 3 | BEARING - PRI PLANET GEAR | 01-105-0570 | 01-105-0570 | 01-105-0570 | 01-105-0570 | 01-105-0570 | 01-105-0570 |
| 26 | * | SHIM - SHAFT ADJUSTMENT | 25-004-1051 | 25-004-1051 | 25-004-1051 | 25-004-1051 | 25-004-1051 | 25-004-1051 |
| 27 | 1 | LOCK RING - LOAD-N-LOCK | 25-004-1192 | 25-004-1192 | 25-004-1192 | 25-004-1192 | 25-004-1192 | 25-004-1192 |
| 28 | 1 | THRUST WASHER - INPUT GEAR | 81-004-2883 | 81-004-2883 | 81-004-2883 | 81-004-2883 | 81-004-2883 | 81-004-2883 |
| | | THRUST WASHER - F/U/W/ 13T 8/16 INPUT | 01-112-0030 | 01-112-0030 | 01-112-0030 | 01-112-0030 | 01-112-0030 | 01-112-0030 |
| 29 | 20 | HEX HEAD CAPSCREW (5/8-11 X 7) GR 8 | 01-150-1630 | 01-150-1630 | 01-150-1630 | 01-150-1630 | 01-150-1630 | 01-150-1630 |
| 30 | 3 | ROLL PIN (3/16 X 1) | 01-153-0020 | 01-153-0020 | 01-153-0020 | 01-153-0020 | 01-153-0020 | 01-153-0020 |
| 31 | 3 | ROLL PIN (3/16 X 1 1/4) | 01-153-0190 | 01-153-0190 | 01-153-0190 | 01-153-0190 | 01-153-0190 | 01-153-0190 |
| 32 | 20 | LOCKWASHER - (5/8) | 01-166-0040 | 01-166-0040 | 01-166-0040 | 01-166-0040 | 01-166-0040 | 01-166-0040 |
| 33 | 1 | PIPE PLUG (1/2 NPT MAGNETIC) - BASE | 01-207-0041 | 01-207-0041 | 01-207-0041 | 01-207-0041 | 01-207-0041 | 01-207-0041 |
| 34 | 1 | PLUG - COVER | 01-208-0030 | 01-208-0030 | 01-208-0030 | 01-208-0030 | 01-208-0030 | 01-208-0030 |
| 35 | 1 | SHAFT SEAL | 01-405-0500 | 01-405-0500 | 01-405-0500 | 01-405-0500 | 01-405-0500 | 01-405-0500 |
| 36 | 1 | PLUG 1/4 NPT | 01-207-0020 | 01-207-0020 | 01-207-0020 | 01-207-0020 | 01-207-0020 | 01-207-0020 |
| | | GREASE FITTING (OPTIONAL) | 01-215-0040 | 01-215-0040 | 01-215-0040 | 01-215-0040 | 01-215-0040 | 01-215-0040 |

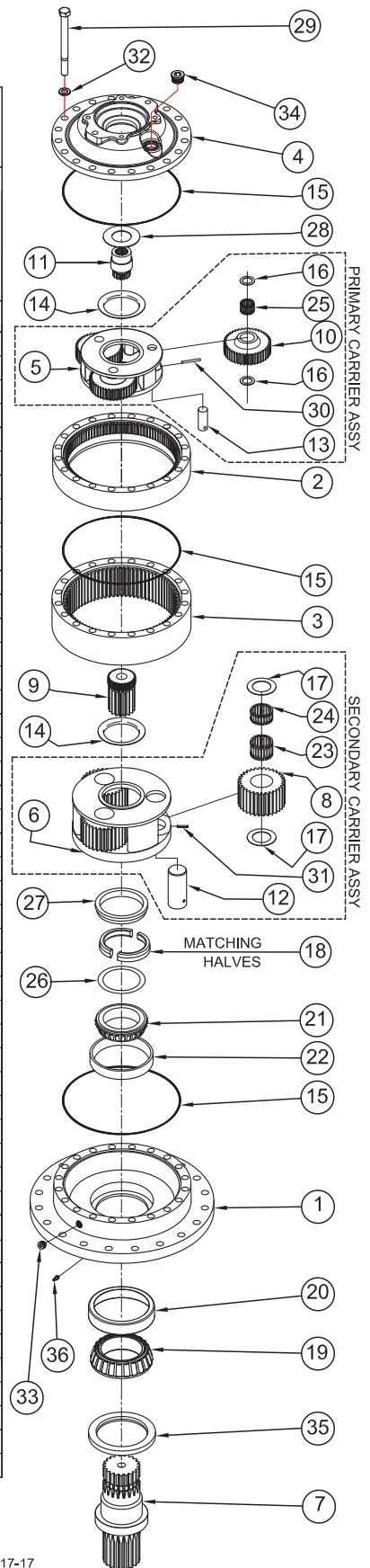

▶ FOR 13T, 8/16 INPUT SPLINE, USE P/N 01-112-0030 THRUST WASHER. (USE ONLY WITH 'D' COVER).

* QUANTITY OF SHIMS DETERMINED BY BEARING PRELOAD.
 OPTIONS SEAL KIT P/N 25-016-2021
 INCLUDES 1 EA. OF ITEMS 35
 AND A QTY 3 OF ITEM 15

E.C.N. 4078
 X250LD2-AD DATE: 04-17-17

X250LD2-AD,
Effective date 1/01/1997
Effective serial # 28500

LUBRICATION & MAINTENANCE

Using the chart below, determine an appropriate lubricant viscosity. Use only EP (extreme pressure) or API GL-5 designated lubricants. Change the lubricant after the first 50 hours of operation and at 500 hour intervals thereafter. The gear drive should be partially disassembled to inspect gears and bearings at 1000 hour intervals.



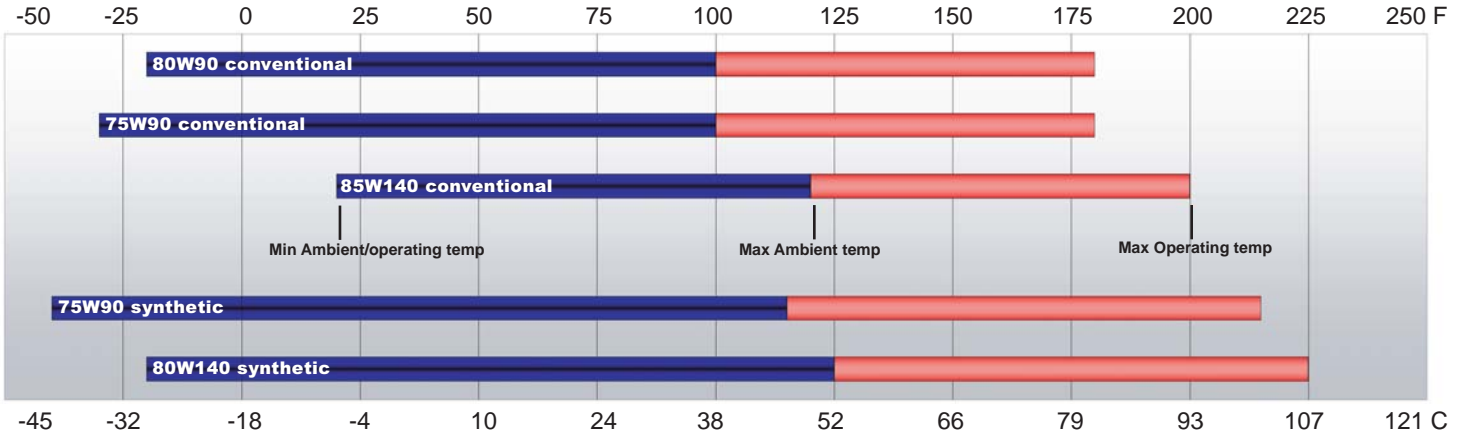



Recommended ambient and operating temperatures for conventional and synthetic gear lubricants



Note: Ambient temperature is the air temperature measured in the immediate vicinity of the gearbox. A Gearbox exposed to the direct rays of the sun or other radiant heat sources will operate at higher temperatures and therefore must be given special consideration. The max operating temp must not be exceeded under any circumstances, regardless of ambient temperature.

If your unit was specified "shaft up" or with a "-Z" option, a grease zerk was provided in the base housing. For shaft-up operation, the output bearing will not run in oil and must be grease lubricated. Use a lithium based or general purpose bearing grease sparingly every 50 operating hours or at regular maintenance intervals. Over-greasing the output bearing should be avoided as it tends to fill the housing with grease and thicken the oil

ESKRIDGE MODEL 250L OIL CAPACITIES

| Operating Position | Oil Capacity | Oil Level |
|--|-----------------|--|
|  Horizontal Shaft | 3.0 qts / 2.8 l | To horizontal centerline of gear drive  |
|  Vertical Shaft (Pinion Up) | 5.0 qts / 4.7 l | To side port on gear drive base  |
|  Vertical Shaft (Pinion Down) | 5.0 qts / 4.7 l | To midway on upper/primary gear set  |

ESKRIDGE PART NUMBER INTERPRETATION

Note: All non custom Eskridge Geardrives are issued a descriptive part number which includes information regarding the Model, means of shaft retention, base style, shaft style, input mounting, input shaft size, overall ratio and various available options. For a detailed breakdown of this information, please refer to Eskridge product specification sheets found at: <http://www.eskridgeinc.com/geardrives/gearprodspecs.html>

Unit Teardown

- 1) Scribe a line across the outside of the unit from the cover (4) to the base (1) before disassembly to aid in the proper positioning of pieces during reassembly.
- 2) Remove drain plugs (33) and drain oil from unit. The oil will drain out more quickly and completely if warm.
- 3) Remove the twenty 5/8-11 capscrews (29) and lockwashers (32).
- 4) Remove the cover (4), thrust washer (28), input gear (11) and carrier thrust washer (14). Inspect o-ring (15); discard if damaged or deformed.
- 5) Lift the planet carrier assembly (includes items 5, 10, 13, 16, 25 & 30) out of the unit.
- 6) If the sun gear (9) has not been removed from the gearbox, do so now. (Sometimes the sun gear remains in the primary carrier (5)).
- 7) Remove the primary ring gear (2). Inspect second o-ring (15), as before; discard if damaged.
- 8) Remove the secondary ring gear (3). Inspect third o-ring (15), as before; discard if damaged.
- 9) Remove carrier thrust washer (14). Lift the secondary planetary assembly out of the unit (includes items 6, 8, 12, 17, 23, 24 & 31). Use a puller if necessary.
- 10) The unit is now disassembled into groups of parts. The area(s) requiring repair should be identified by thorough inspection of the individual components after they have been cleaned and dried.

Carrier Assembly Teardown

Rotate planet gears (10 pri/8 sec) to check for abnormal noise or roughness in bearings (25 pri/23, 24 sec). If further inspection or replacement is required, proceed as follows.

- 1) Drive roll pins (30 pri/31 sec) completely into the planet shafts (13 pri/12 sec).
- 2) Slide planet shafts (13 pri/12 sec) out of carrier (5 pri/6 sec).
- 3) Remove planet gears (13 pri/12 sec), washers (16 pri/17 sec), and bearings (25 pri/23, 24 sec) from carrier (5 pri/6 sec).
- 4) Inspect the planet gear (10 pri/8 sec), bearing bore and planet shaft (13 pri/12 sec) and bearing rollers and cage (25 pri/23, 24 sec). Check for spalling, bruising or other damage and replace components as necessary. *Note: When bearing and cage must be replaced, it is possible the planet shafts and planet gear may need to be replaced as well; inspect carefully.*
- 5) Remove roll pins (30 pri/31 sec) from planet shafts (13 pri/12 sec) using a 1/16 pri/ 3/16 sec inch pin punch.

Carrier Reassembly

- 1) Install bearings (25 pri/23, 24 sec) into planet gear (10 pri/8 sec). Put a thrust washer (16 pri/17 sec) on top and bottom of planet gear (10 pri/8 sec).

- 2) Slide the gear with thrust washers into the carrier (5 pri/6 sec).
- 3) Planet shafts (13 pri/12 sec) should be installed with chamfered end of 1/16 pri/ 3/16 sec inch roll pin hole towards outside diameter of carrier (5 pri/6 sec); this will ease alignment of holes while inserting roll pins (30 pri/31 sec).
- 3) Drive roll pin (30 pri/31 sec) into the carrier hole and into planet shaft to retain parts. Repeat for remaining planet gears.

Base Subassembly Teardown

- 1) Remove the lock ring (27) using a heel bar or puller; if using a heel bar, be sure **not** to pry against the cage of the inner output shaft bearing (21). Remove the split ring segments (18) and shims (26).

Caution: Since the shaft is no longer positively retained, care should be taken to avoid personal injury. Care should also be taken not to damage it while pressing through base.

Note: Removing the shaft from the base assembly damages the shaft seal (35) and the seal will need to be replaced.

- 2) Place base (1) external side down, on a plate or table. Press output shaft (7) out bottom of base (1) by applying a load to internal end of shaft until it passes through inner shaft bearing cone (21).
- 3) A gear puller may be used to remove the outer bearing cone (19) from the shaft (7). If reusing old bearing cone, do not pull on or damage roller cage. Remove the shaft seal (35) for replacement.
- 4) Lubricate inner lip of new shaft seal (35) and slide it onto the shaft (7) until it fits snugly over the shaft seal diameter with the open side toward the inside of the gear drive.

Note: Press bearing cone onto output shaft by pressing on inner race only. DO NOT press on roller cage, as it will damage bearing.

- 5) Inspect inner and outer bearing cups (22 & 20). If cups are damaged, drive them out using a brass drift and utilizing the bearing knock-out notches in the base (1)

Base Reassembly

- 1) Clean all foreign material from magnetic oil plug located on base (1).
- 2) Place base (1) exterior side up on work table.
- 3) Apply a layer of lithium or general purpose bearing grease to the roller contact surface of outer bearing cup (20). If unit is a spindle-shaft style and if equipped with optional boot (01-406-0050), install boot now.
- 4) Press outer bearing cone (19) onto the shaft until it seats against the shoulder.
- 5) Place the shaft (7) with the bearing (19) and seal (35) into the base (1). For a spindle shaft, use either a split-type spacer with handles on it to force seal into bore without damaging the seal can or use 4 (or more) 1" wide bars 1/2"

thick to force seal can into seal bore. Spread an even layer of Loctite 645 purple or similar thread-sealant on O.D. of seal can prior to installation.

- 6) Flip shaft/base assembly, and, for spindle-shaft units, press on base (1) to install seal (35) into seal-bore of base (1); pull the seal-installation tools out from around the base/seal. Apply lithium or general purpose bearing grease to roller contact surface of the inner cup (22)., then press inner bearing cone (21) onto shaft (7) until it seats against inner bearing cup (22).
- 7) Prior to installation of the shaft seal (35) (for non-spindle-shaft units), the preload may result in a rolling torque which varies between 70 to 115 in-lb. The bearing preload should be tailored to your application; a low-speed application may require a high pre-load, while high-speed applications usually benefit from low pre-load. Adding shims (26) will increase the pre-load on the bearing set. Determine your pre-load requirement and install shims (26) to obtain this pre-load.

Install the Load-N-Lock™ segments (18) over the shims (26) and into the groove in the shaft (7). Finally, install the lock ring (27) over the segments (18).

All subassembly service or repairs should be complete at this time. Continue to Unit Assembly to complete unit buildup.

Unit Reassembly

- 1) Install the secondary carrier (6) assembly onto the output shaft (7); align the splines of the carrier (6) with the output shaft (7) splines and slide the carrier onto the shaft.
- 2) Lubricate o-ring(s) (15) and install on the secondary ring gear (3) pilot. Referring to the scribe marks for proper orientation, install the secondary ring gear (3) onto the base (1)

Caution: Hold ring gear(s) by outside diameter or use lifting device to prevent injury.

- 3) Align gear teeth of secondary ring gear (3) with the gear teeth of the planet gears (8) and then align the bolt holes and the scribe line and work the ring gear down into the pilot of the base (1).
- 4) Lubricate o-ring (15) and install on the outside diameter of pilot of the primary ring gear (2) and install the primary ring gear (2). Refer to scribe marks for proper orientation.
- 5) Install the sun gear (9) into the secondary planet carrier (6).
- 6) Install the carrier thrust washer (14).
- 7) Install primary planet carrier (5) assembly by rotating it and planet gears until the planet gear (10) teeth line up with the ring gear (2) teeth and sun gear (9) spline. Assembly should drop into place.
- 8) Slide the input gear (11) into the primary planetary carrier (5) assembly.
- 9) Install the carrier thrust washer (14) and input gear thrust washer (28).
- 10) Tighten four bolts, placed at 90° to each other, just enough to

pull ring gears and base together. Spin test the unit while making sure the base or output shaft turns at least one full revolution; the unit should spin freely without any binding, slowing down or locking of components. Listen for any unusual sounds, such as clicking or grinding noises.

If no problems are detected, continue to Step 11. If the unit locks up or does not spin freely, tear the unit down to its individual subassemblies; troubleshoot to identify the source of the problem. Correct and continue.

- 11) Remove the 4 bolts from above. Lubricate o-ring (15) and install on the O.D. pilot of the cover (4). with the proper orientation. Install the twenty 5/8-11 capscrews (29) with lockwashers (32) and torque to 220 ft-lbs (dry), 170 ft-lbs (lubed).
- 12) Fill to proper level, as specified on Page 2, with EP 80/90 gear oil after unit is sealed with a brake and/or motor.

The gearbox is now ready to use.