

MODEL D36K

D36K-1600
D36K-2000
D36K-2800

Planetary Auger Drive Service & Repair Manual

EFFECTIVE FOR:
S/N: 16401 - UP
DATE: 07/01/93 - UP

MODEL D36K SERVICE MANUAL

SINGLE (D36K-1600 D36K-2000) & DOUBLE (D36K-2800)

PLANETARY AUGER DRIVES

This manual will assist in disassembly and assembly of major components for all Model D36K Planetary Auger Drives. Item numbers, indicated in parentheses throughout this manual, refer to the Eskridge Model D36K exploded parts breakdown drawings. Individual customer specifications (bail assembly, output shaft, hydraulic motor, etc.) may vary from exploded drawing and standard part numbers shown. If applicable, refer to individual customer drawing for details.

LUBRICATION AND MAINTENANCE

The oil should be changed after the first 50 hrs. of use and at 500 hr. intervals thereafter. Gearboxes in auger drives require GL-5 grade EP 80/90 gear oil for lubrication. The manufacturer recommends that the unit be partially disassembled to inspect gears, splines, and bearings at 1000 hour intervals.

OIL CAPACITY: 2 PINTS

Oil level should be checked by laying the unit on its side, with the oil check plug 30 degrees from the top.

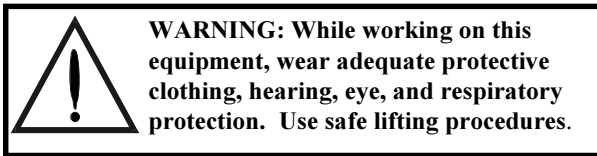

BEFORE DISASSEMBLY

There are two types of units: Single planetary without a primary planet carrier and double planetary with a primary planet carrier. **Steps with an asterisk (*) apply only to the double planetary models.**

UNIT DISASSEMBLY

(Refer to exploded view drawings on pages 6 & 7)

1) Scribe a diagonal line, from the bail assembly (41) to the case (1), across the outside of the auger drive to assure proper orientation of parts as they are re-assembled.

2) To drain oil, position unit on its side and remove oil plug (32) located in the case (1). To help ventilate oil while draining, loosen hydraulic motor bolts (37). Maximum drainage occurs when oil is warm.

NOTE: Particular care should be taken when placing the unit in a position for servicing. Unit should be blocked up so that weight of the unit is resting on the case (1). This fixture must be secure so that the auger drive will not tip over during disassembly and assembly procedures.

3) Remove the six hex head cap screws (39) from bail assembly (41). Lift bail assembly from unit.

4) Remove the two cap screws (37) and lock washers (36) from hydraulic motor (38). Remove motor from unit.

5) Remove the twelve hex capscrews (27) and lockwashers (31).

6) Remove cover (3), input thrust washer (26), and input gear (12).

*7) Lift the primary planet carrier assembly out of the unit (includes items 6,8,14,15,17,25, & 30).

*8) If sun gear (11) has not been removed from auger drive, do so now. (Sometimes the sun gear remains in the primary carrier (6).)

NOTE: Care should be taken not to damage parts or o-ring groove when prying ring gear from case.

9) There are four dowel bushings (28) connecting the ring gear (2) to case (1). Two pry bars may be used at joint between ring gear and case to separate parts.

10) Lift the secondary planet carrier assembly out of the unit (includes items 5,7,13,15,16,24, & 29). Use a puller if needed.

11) The unit is now disassembled into groups of parts. The area(s) requiring repair should be identified by thorough inspection of the parts after they have been cleaned and dried. Then refer to the appropriate group repair section below.

- *1. Primary Planet Carrier subassembly
- 2. Secondary Planet Carrier subassembly
- 3. Case subassembly

*PRIMARY PLANET CARRIER SUBASSEMBLY (ITEMS 6,8,14,17,25,26, & 30) DISASSEMBLY AND REPAIR

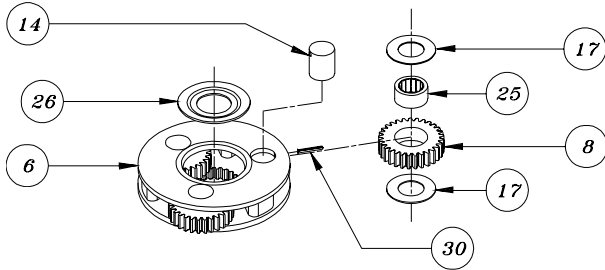

*Rotate planet gears (8) to check for abnormal noise or roughness in bearings (25) or planet shafts (14). If further inspection or replacement is required, proceed as follows.

- *1) Drive roll pins (30) completely into planet shafts (14).
- *2) Press or drive planet shafts (14) out of carrier (6).
- *3) Remove planet gears (8) and washers (17) from the carrier (6).
- *4) If the planet bearings (25) require replacement, press them out of the planet gears (8) and replace with new ones.
- *5) Check primary planet shafts (14) for any abnormal wear, especially ones where bearings needed to be replaced. If any abnormal wear is found, replace planet shafts.
- *6) Remove the roll pins (30) from planet shafts (14).
- *7) With washers (17) on both sides of the planet gear (8) and with bearings (25) installed, slide gear into the carrier (6). Insert the planet shaft (14) through the carrier, washers, and planet gear.
- *8) Planet shafts (14) should be installed with chamfered end of 1/8 inch hole toward outside diameter of the carrier (6). This will aid in alignment of holes while inserting roll pins (30).
- *9) Drive three roll pins (30) through the carrier holes and into the planet shafts to retain the parts.

SECONDARY PLANET CARRIER SUBASSEMBLY (ITEMS 5,7,13,15,16,24, & 29) DISASSEMBLY AND REPAIR

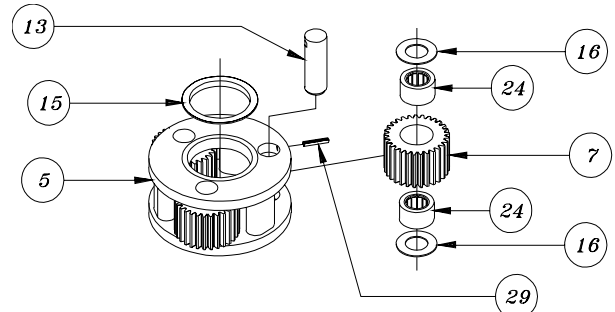

Follow the same procedure as that for the PRIMARY PLANET CARRIER SUBASSEMBLY. Substitute items as indicated: planet gears (7), planet bearings (24), planet shafts (13), washers (16), and carrier (5).

CASE SUBASSEMBLY

(ITEMS 1,4,10,18,19,
20,21,22,23,28,32,33, & 34)
DISASSEMBLY AND REPAIR

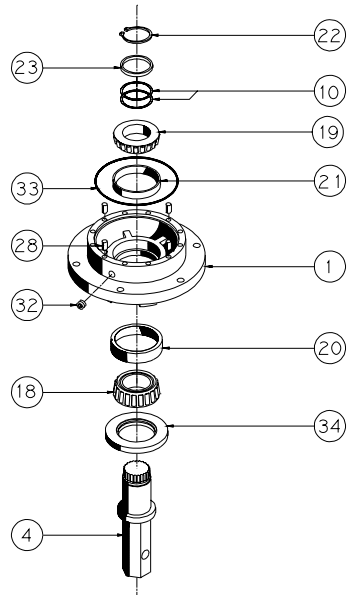

1) Case (1) should be set pinion side down, as shown, on a plate or table with output shaft (49) protruding through a hole in table.

2) Remove retaining ring (22).

CAUTION: Output shaft is no longer retained. Care should be taken not to injure feet because output shaft can fall out. Care should also be taken not to damage output shaft when shaft is pressed through case.

3) Press output shaft out bottom of case by applying a load to top end (**internal end**) of shaft until it passes through inner shaft bearing cone (19). Outer bearing cone (18) will be attached to shaft.

4) Inspect inner bearing cone (19).

NOTE: If reusing old bearing cone, do not damage roller cage by pulling on it.

5) If outer bearing cone (18) needs to be replaced, it will need to be pressed off of output shaft. In some instances, outer bearing cone (18) may need to be removed to replace shaft seal (34).

6) If necessary, remove the shaft seal (34) for inspection or replacement. Lubricate inner lip of new shaft seal (34) and slide the seal onto the shaft (4) until it fits snugly over shaft seal diameter with the open side toward the inside of the auger drive.

7) Inspect inner and outer bearing cups (21 & 20) and replace if necessary.

4

* applies only to the double planetary models.

CASE ASSEMBLY

NOTE: Press bearing cone onto output shaft by pressing on inner race only. DO NOT press on roller cage or it may damage bearing.

1) If outer bearing cone (18) was removed for replacement, press a new bearing cone (**large end down as shown**) onto the shaft until it seats against the shoulder.

2) Place the case (1) (**output side up, opposite shown**) on the press table.

3) Apply a layer of lithium or general purpose bearing grease to surface of outer bearing cup (20). Insert the shaft (4) into the case (1) (**bearing cone down**) and use a soft hammer to install the shaft seal (34) into the case.

CAUTION: Output shaft is not retained at this point.

4) Invert this assembly so it is standing on the shaft (**on the press table**).

NOTE: Press bearing cone onto output shaft by pressing on inner race only. DO NOT press on roller cage or it may damage bearing.

5) Apply a layer of lithium or general purpose bearing grease to surface of inner bearing cup (21). Press the inner bearing cone (19) (**large end up as shown**) onto the shaft (4) until it is seated against inner bearing cup (21).

SHAFT BEARING PRELOAD: Proper shaft bearing preload is achieved when torque required to rotate case is 10 to 50 in-lbs. This rolling torque is equal to a force of approximately 3 to 11 lbs if pulling on mounting case flange to rotate case (1). This may be determined by feel or by using a fish scale or similar measuring device to check rolling torque. Once preload is set, relieve press load.

6) Install shim(s) (10), spacer (23), and retaining ring (22) onto the output shaft (4). Check bearing preload, add or remove shims as required.

NOTE: Retaining ring must be fully seated into groove.

All subassembly service or repairs should be complete at this point. Continue on through UNIT ASSEMBLY to complete unit buildup.

UNIT ASSEMBLY REASSEMBLING

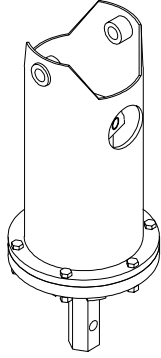

(Refer to exploded drawing on page 9)

1) When all subassemblies are complete, unit is ready to be assembled. Place lower assembly back on blocks, which were used during the initial UNIT DISASSEMBLY procedures, for remaining unit build-up.

2) Install a new o-ring (33) on the case (1).

3) Install the planet carrier (5) assembly by rotating it until carrier spline lines up with shaft spline.

4) Install thrust washer (15).

5) Referring to scribe marks for proper orientation, install the ring gear (2) by rotating until ring gear teeth line up with planet gears.

*6) Slide the sun gear (11) into the secondary planet carrier (5).

*7) Install the primary carrier (6) by rotating until spline lines up with sun gear . It may be easier to install the sun gear (11) into the bottom of the primary carrier and then install primary carrier.

8) Slide the input gear (12) into the planetary carrier (5).

9) Install input thrust washer (26) over step of input gear (12).

10) Install a new o-ring (33) onto cover (3). Position the cover with proper orientation to scribed line on outside of unit.

11) Install twelve lockwashers (31) and hex capscrews (27) and torque to 20 ft.-lbs.

12) Mount motor (38) with gasket (35). Torque bolts (37) to 55 ft.-lbs. Lift bail housing onto rotation assembly. Align access hole with motor ports. Secure with six bolts (39), lockwashers (40), and nuts (42). Torque to 55 ft.-lbs.

13) Fill to proper level, as specified on page 2, with EP 80/90 gear oil.

THE AUGER DRIVE IS NOW READY TO USE.

* applies only to the double planetary models.

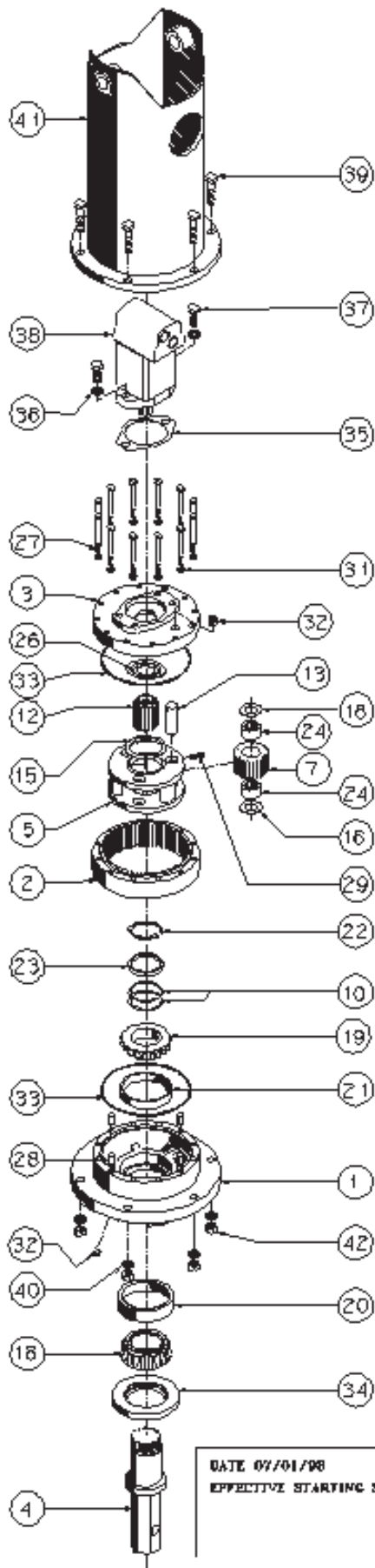

42	6	01-158-0060	HEX NUT (1/2-13 ZINK PL)
41	1	85-005-8062	BAIL ASSY
40	6	01-166-0030	LOCKWASHER (1/2 MED)
39	6	01-150-0920	HHCS 1/2-13 X 2.25 GR5
38	1	-B-	MOTOR
37	2	01-150-0250	HHCS 1/2-13 X 1.25 GR5
36	2	01-166-0030	LOCKWASHER (1/2 MED)
35	1	90-004-1061	GASKET
34	1	01-405-0530	SEAL - SHAFT
33	2	01-402-0560	O-RING (167 X 3 MM)
32	2	01-207-0070	PLUG - MAGNETIC 3/8NPT-SOC HD
31	12	01-166-0110	LOCKWASHER 5/16 MED
30			
29	3	01-153-0210	ROLLPIN - 3/16X7/8
28	4	01-152-0110	DOWEL BUSHING (5/16 X 3/4)
27	12	01-150-1340	HEX CAPSCREW 5/16-18 X 3.25 GR8
26	1	50-004-1091	THRUST WASHER - INPUT
25			
24	6	01-105-0010	BEARING - PLANET GEAR
23	1	50-004-1101	SPACER
22	1	01-160-0430	RETAINING RING
21	1	01-103-0140	BEARING CUP (INNER)
20	1	01-103-0130	BEARING CUP (OUTER)
19	1	01-102-0150	BEARING CONE (INNER)
18	1	01-102-0140	BEARING CONE (OUTER)
17			
16	6	85-004-1181	PLANET WASHER
15	1	50-004-1011	THRUST WASHER SEC. CUP
14			
13	3	71-004-0121	PLANET SHAFT
12	1	85-004-1272	INPUT GEAR-6B
11			
10	-A-	85-004-1221	SHIM - BEARING
9	-	-	-
8			
7	3	85-004-1051	PLANET GEAR
6			
5	1	50-004-1062	CARRIER
4	1	50-004-4082	OUTPUT SHAFT-2" HEX
3	1	85-004-1513	COVER-SAE "A"
2	1	85-004-1283	RING GEAR
1	1	85-004-1344	CASE
1_{EM}	Q_{1Y}	PART NO.	DESCRIPTION

NOTE	DESC.	PART NUMBER	
		D36-1600	D36-2000
-B-	MOTOR	01-304-0260	01-304-0270

NOTE -A- BEARING PRELOAD DETERMINES QUANTITY OF SHIMS.
SEAL KIT P/N B5-016-0601 INCLUDES (2EA) O-RINGS AND (1EA) SEAL

DATE 07/01/98
EFFECTIVE STARTING S/P 18401



D36K-1600
D36K-2000
PLANETARY
AUGER DRIVE

W 15EPV036W390L

DATE 08/22/85

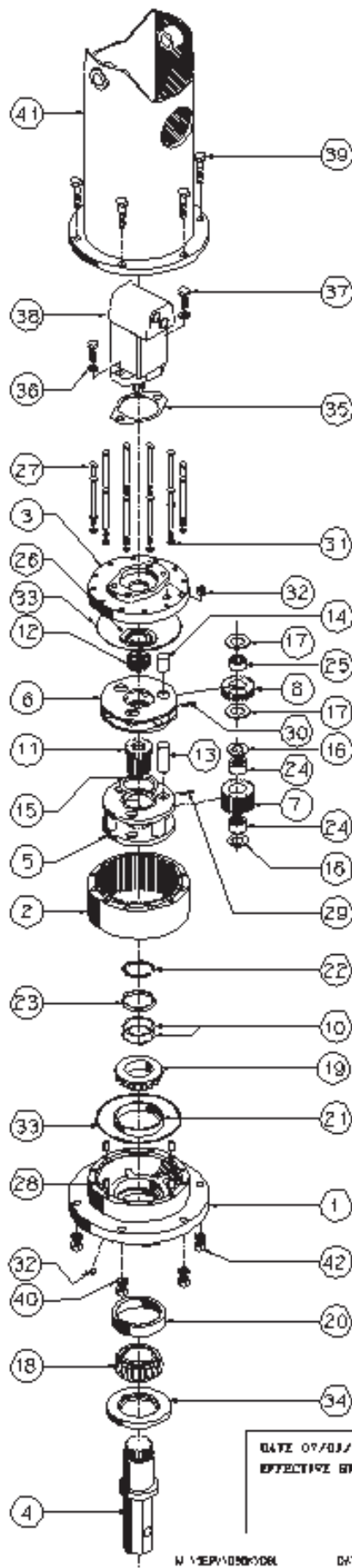

42	6	01-158-0060	HEX NUT (1/2-13 ZINK PL.)
41	1	85-005-8062	BAIL ASSY
40	6	01-166-0030	LOCKWASHER (1/2 MED)
39	6	01-150-0920	HHCS 1/2-13 X 2.25 GR5
38	1	01-304-0280	MOTOR
37	2	01-150-0250	HHCS 1/2-13 X 1.25 GR5
36	2	01-166-0030	LOCKWASHER (1/2 MED)
35	1	90-004-1081	GASKET
34	1	01-405-0530	SEAL - SHAFT
33	2	01-402-0560	O-RING [167 X 3 MM]
32	2	01-207-0070	PLUG - MAGNETIC 3/8NPT-SOC HD
31	12	01-166-0110	LOCKWASHER 5/16 MED
30	3	01-153-0080	ROLLPIN - PRI 1/8X1
29	3	01-153-0210	ROLLPIN - SEC 3/16X7/8
28	4	01-152-0110	DOWEL BUSHING (5/16 X 3/4)
27	12	01-150-1280	HEX CAPSCREW 5/16-18 X 4 5 GR8
26	1	50-004-1091	THRUST WASHER - INPUT
25	3	01-105-0410	BEARING - PRI PLANET GEAR
24	6	01-105-0010	BEARING - SEC PLANET GEAR
23	1	50-004-1101	SPACER
22	1	01-160-0430	RETAINING RING
21	1	01-103-0140	BEARING CUP (INNER)
20	1	01-103-0130	BEARING CUP (OUTER)
19	1	01-102-0150	BEARING CONE (INNER)
18	1	01-102-0140	BEARING CONE (OUTER)
17	6	81-004-1561	PLANET WASHER - PRI PLANET
16	6	85-004-1181	PLANET WASHER - SEC PLANET
15	1	50-004-1011	THRUST WASHER SEC. - CUP
14	3	81-004-0071	PLANET SHAFT - PRI
13	3	71-004-0121	PLANET SHAFT - SEC
12	1	85-004-1122	INPUT GEAR - 6B
11	1	85-004-1092	SUN GEAR - SEC
10	-A-	85-004-1221	SHIM - BEARING
9	-	-	-
8	3	85-004-1031	PLANET GEAR - PRI
7	3	85-004-1051	PLANET GEAR - SEC
6	1	50-004-1082	CARRIER-PRI
5	1	50-004-1062	CARRIER-SEC
4	1	50-004-4082	OUTPUT SHAFT - 2" HEX
3	1	85-004-1513	COVER - SAE 'A'
2	1	85-004-1173	RING GEAR
1	1	85-004-1344	CASE
I_{EM}	Q_V	PART NO.	DESCRIPTION

NOTE -A- BEARING PRELOAD DETERMINES QUANTITY OF SHIMS.
SEAL KIT P/N 85-016-0801 INCLUDES (2EA) O-RINGS AND (1EA) SEAL.

DATE 07/03/88
EFFECTIVE REVISION 6/20 18403



M 13EP1086700K

DATE 06-02-89

PRODUCT WARRANTY

ESKRIDGE, INC. ("Eskridge") warrants to its original purchaser ("Customer") that new component parts ("Parts") sold by Eskridge to the Customer will be free of defects in material and workmanship and will conform to standard specifications set forth in current Eskridge sales literature or to any custom specifications of the Customer acknowledged in writing by Eskridge, **SUBJECT TO THE FOLLOWING QUALIFICATIONS AND LIMITATIONS:**

- 1) Prior to placing warranted Parts in service, the Customer shall provide proper storage such that foreign objects (e.g., rain or debris) cannot enter any Parts via entry ports which are normally closed during operation.
- 2) If Parts requiring motorized power for operation are received from Eskridge without a motor, documentation must be available indicating proper lubrication upon placement of the Parts in service.
- 3) The Customer must notify Eskridge in writing of any claim for breach of this warranty promptly after discovery of a defect and in any event prior to the termination of the warranty period, which shall commence when a unit is placed in service and shall expire upon the earlier of (i) the expiration of twelve (12) months from the date of Commencement of Service (as defined in Paragraph 4) (ii) the completion of one thousand (1,000) hours of service of the Parts (iii) the expiration of six (6) months after the expiration of any express warranty relating to the first item of machinery or equipment in which the Parts are installed or on which it is mounted, or (iv) the installation or mounting of the Parts in or on an item of machinery or equipment other than the first such item in which the Parts are installed or on which the Parts are mounted.
- 4) Parts shall be deemed to have been placed in service (the "Commencement of Service") at the time the machinery or equipment manufactured or assembled by the Customer and in which the Parts are installed or on which the Parts are mounted is delivered to the Customer's dealer or the original end-user, whichever ever receives such machinery or equipment first.
- 5) This warranty shall not apply with respect to Parts which, upon inspection by Eskridge, show signs of disassembly, rework, modifications or improper installation, mounting, use or maintenance.
- 6) Eskridge makes no warranty in respect to hydraulic motors mounted on any Parts. Failure of any such motor will be referred to the motor manufacturer.
- 7) Claims under this warranty will be satisfied only by repair of any defect(s) or, if repair is determined by Eskridge in its sole, absolute and uncontrolled discretion to be impossible or impractical, by replacement of the Parts or any defective component thereof. No cash payment or credit will be made for defective materials or workmanship. **IN NO EVENT SHALL ESKRIDGE BE LIABLE FOR INCIDENTAL OR CONSEQUENTIAL DAMAGES OF ANY KIND OR NATURE, WHICH DAMAGES ARE HEREBY EXPRESSLY DISCLAIMED.**
- 8) From time to time, Eskridge may make changes in the component parts manufactured by it without incorporating such changes in the component parts previously shipped. Such changes shall not constitute an admission by Eskridge of any defects or problems with previously manufactured component parts.
- 9) All freight charges on Parts returned for warranty service are the responsibility of the Customer.

THE FOREGOING WARRANTY IS THE SOLE WARRANTY MADE BY ESKRIDGE WITH RESPECT TO ANY PARTS, AND IS IN LIEU OF ANY AND ALL OTHER WARRANTIES, EXPRESSED OR IMPLIED. THERE ARE NO WARRANTIES WHICH EXTEND BEYOND THE DESCRIPTION ON THE FACE HEREOF. WITHOUT LIMITING THE GENERALITY OF THE FOREGOING, ESKRIDGE EXPRESSLY DISCLAIMS ANY IMPLIED WARRANTY OF MERCHANTABILITY OR FITNESS FOR ANY PARTICULAR PURPOSE, REGARDLESS OF ANY KNOWLEDGE ESKRIDGE MAY HAVE OF ANY PARTICULAR USE OR APPLICATION INTENDED BY THE PURCHASER. THE SUITABILITY OR FITNESS OF THE PARTS FOR THE CUSTOMER'S INTENDED USE, APPLICATION OR PURPOSE AND THE PROPER METHOD OF INSTALLATION OR MOUNTING MUST BE DETERMINED BY THE CUSTOMER.

WARRANTY RETURN POLICY

- 1) All Parts shall be returned freight prepaid.
- 2) Any Parts qualifying for warranty will be repaired with new Parts free of charge (except for freight charges as provided above).
- 3) If parts are found to be operable, you have two options:
 - a. The Parts can be returned to you with a service charge for inspection, cleaning, and routine replacement of all rubber components and any other parts that show wear; or
 - b. We can dispose of the Parts at the factory if you do not wish it to be returned.

NOTE: Any order of Parts by customer shall only be accepted by Eskridge subject to the terms stated herein. Any purchase order forms used by Customer (to accept this offer to sell) which contain terms contrary to, different from, or in addition to the terms herein shall be without effect, and such terms shall constitute material alteration of the offer contained herein under K.S.A 84-2-207 (2)(b), and shall not become part of the contract regarding the sale of the Parts.

OTHER ESKRIDGE PRODUCTS

PLANETARY GEARDRIVES

SERIES

20/28 SERIES
50 SERIES
60 SERIES
100 SERIES
130 SERIES
150 SERIES
250 SERIES
600 SERIES
1000 SERIES

TORQUE RATING

MAX. INTERMITTENT
20,000-28,000 IN-LBS
50,000 IN-LBS
60,000 IN-LBS
100,000 IN-LBS
130,000 IN-LBS
150,000 IN-LBS
250,000 IN-LBS
600,000 IN-LBS
1,000,000 IN-LBS

MULTIPLE DISC BRAKES

SERIES

90B SAE B
90BA SAE B ADJUSTABLE TORQUE
92B SAE B LOW PROFILE
93 FOR NICHOLS MOTORS
95C SAE C
95W WHEEL MOUNT
98D SAE D

TORQUE RATING
TO 4,800 IN-LBS
TO 4,800 IN-LBS
TO 2,800 IN-LBS
TO 6,100 IN-LBS
TO 12,000 IN-LBS
TO 21,000 IN-LBS
TO 25,000 IN-LBS

PLANETARY AUGER DRIVES (DIGGERS)

SERIES

D50 MODELS 1500, 2500 & 5000
76 MODELS BA & BC, TWO SPEED
77 MODELS BA, BC & BD
78 MODELS 35 & 48, TWO SPEED
75 MODELS 38 & 51, TWO SPEED

TORQUE RATING
1,500-5,000 FT-LBS
8,000-12,500 FT-LBS
6,000-12,500 FT-LBS
9,000-12,500 FT-LBS
16,500-20,000 FT-LBS



1900 Kansas City Road
Olathe, Kansas 66061
phone (913) 782-1238
fax (913) 782-4206

WEBSITE: www.eskridgeinc.com
E-MAIL: sales@eskridgeinc.com

Your nearest Eskridge Distributor is:

